

Style C

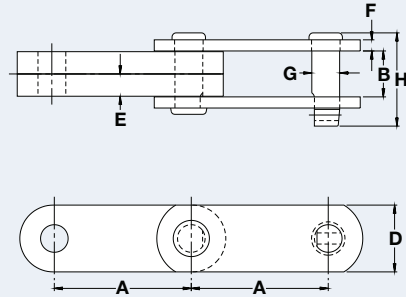

Style D

Engineering Class Steel Block Chain

Dimensions are in inches unless otherwise indicated.

Chain No.	Sidebar Style	Pitch	Inner Width Max	Plate Height Max	Inner Plate Thick Max	Outer Plate Thick Max	Pin Diam Max	Pin Length Max	Average Ultimate Strength	Weight
		A	B	D	E	F	G	H	Lbs	Lbs/Ft
131M	D	3.075	1.000	1.500	0.500	0.250	0.625	2.090	30,000	4.10
1127	C	4.000	0.875	1.500	0.875	0.375	0.625	2.250	30,700	5.70
1301	C	4.000	1.060	2.000	1.000	0.750	0.875	3.250	67,000	12.60
526M	C	6.000	0.938	1.500	0.875	0.375	0.625	2.203	49,000	5.12
1236P	C	6.000	1.031	1.500	1.000	0.310	0.625	2.250	51,000	5.10
526PM	C	6.000	0.938	1.500	0.875	0.375	0.625	2.203	76,500	5.12
313R	C	6.000	1.060	2.000	1.000	0.500	0.875	2.750	77,500	9.10
1338	C	8.000	1.625	3.000	1.500	0.625	1.250	3.750	95,000	19.00
119P	D	8.000	1.531	2.000	0.750	0.750	0.875	3.719	100,000	12.50
1362A	C	8.000	1.063	2.000	1.000	0.500	1.125	2.310	100,000	8.30
1373A	C	8.000	1.563	2.500	1.500	0.750	1.125	3.906	222,000	16.50
1348P	C	8.000	1.594	3.000	1.500	0.750	1.500	4.250	230,000	20.00
1342R	C	10.000	2.094	3.000	2.000	1.000	1.500	4.688	340,000	26.00
1313	C	10.000	2.625	3.500	2.500	1.250	1.750	6.297	450,000	39.00

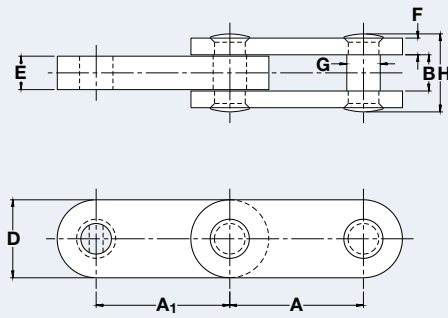

Style C

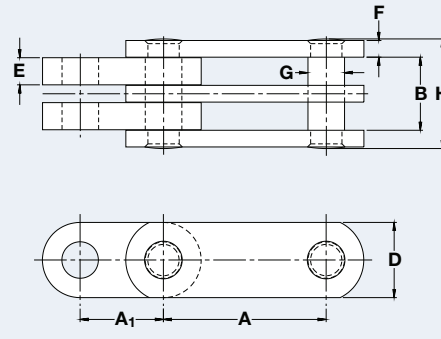

Style E

Engineering Class Draw Bench Chain

Dimensions are in inches unless otherwise indicated.

Chain No.	Sidebar Style	Pitch		Inner Width Max	Plate Height Max	Inner Plate Thick Max	Outer Plate Thick Max	Pin Diam Max	Pin Length Max	Average Ultimate Strength	Weight
		A	A ₁								
1413A	C	3.000	3.000	0.813	1.750	0.750	0.375	0.750	1.750	83,000	7.00
1445A	C	5.000	3.250	1.219	2.250	1.125	0.500	1.125	2.410	160,000	12.00
1416P	C	6.000	3.250	1.313	2.500	1.250	0.625	1.250	2.688	160,000	15.30
1418B	C	8.500	4.750	2.063	4.000	2.000	0.875	2.000	3.940	300,000	37.70
1465AR	C	8.500	4.250	1.563	4.000	1.500	0.750	2.000	3.375	415,000	30.60
1439AR	C	8.500	4.250	2.062	4.000	2.000	1.000	1.990	4.375	550,000	40.40
1395AR	E*	9.750	5.000	4.375	4.500	1.625	1.000	2.190	6.500	1,000,000	68.40
4198A	E*	9.750	5.000	5.810	4.500	2.250	1.120	2.375	8.438	1,000,000	89.00
4298A	E*	9.750	5.000	9.120	4.500	2.250	1.120	2.375	11.750	1,500,000	134.00

*Multiple-Leaf Type