

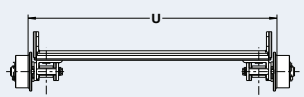

## Applications

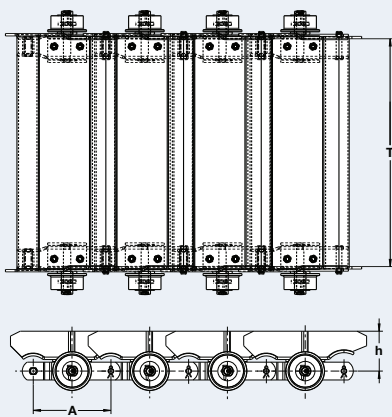

## Types of Apron Conveyors



Outboard Roller Apron

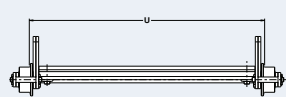
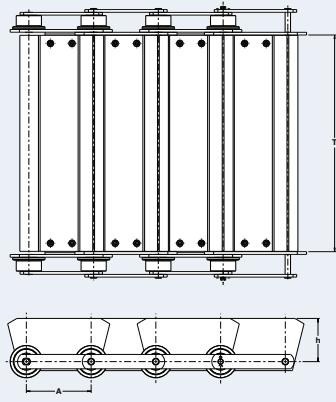

Inboard Roller Apron

- A = Pitch
- E = Pan Thickness
- h = End Height
- T = Pan/Flight Width
- U = Track Gauge Width

## Types of Pan Flights

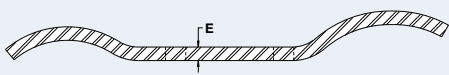

Style A  
Fastened above centerline of chain

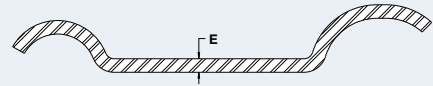

Style A-1  
Fastened on centerline of chain

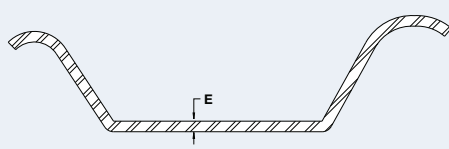

Deep Pan Style

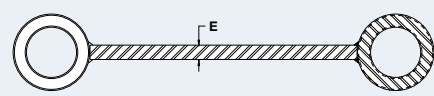

Piano Hinge Style  
Fastened with thru rod