

Dairy Case Conveyor Chains

**RENOLD
JEFFREY**

- Versatile performance
- Superior strength
- Extended wear life

Building A Strong Yet Flexible Case

Renold Jeffrey DF3500 and DF3498 Chains have what it takes to optimize efficiency in today's high-production dairy plants — as well as bakeries, water bottling plants, and large distribution warehouses.

Dairy Case Conveyor Chains from Renold Jeffrey are versatile performers. These heavy-duty, multi-flex, in-floor conveyor chains can make several turns in a single run, saving transfer points and floor space with a compact layout.

DF3500 and DF3498 Chains are specifically designed to handle the heavy case weights and variable shock loads inherent in modern dairy plants. Specially selected heat-treated alloy steels provide superior strength. Induction hardened pins and sliding surfaces extend wear life. Cupped outer sidebars facilitate flexing and protect pins from wear. The end result is strong, long-lasting, reliable operation.

Contact your local distributor or Renold Jeffrey to get Dairy Case Conveyor Chains that are the cream of the crop.

Dairy Case Conveyor Chains



In Stock

- Versatile in-floor operation
- Compact conveyor layout
- Strong, reliable performance

Chain No.	Block Link Width (in.)	Height of Sidebar (in.)	Pin Dia. (in.)	Width (in.)	Rated Working Load (lbs.)	Min. Flex Radius (in.)	Ave. Chain Weight (lbs./ft.)
	B	D	G	H			
DF3500	.625	1.250	.570	1.500	4,000	20.0	3.5
DF3498	.625	1.380	.625	1.560	5,000	16.0	4.5

DF3500

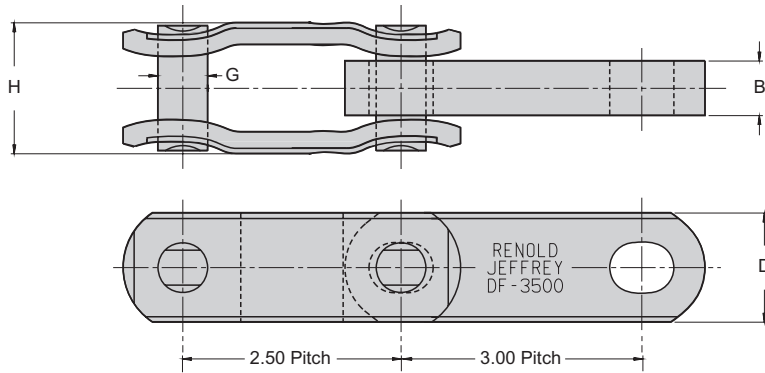

DF3498

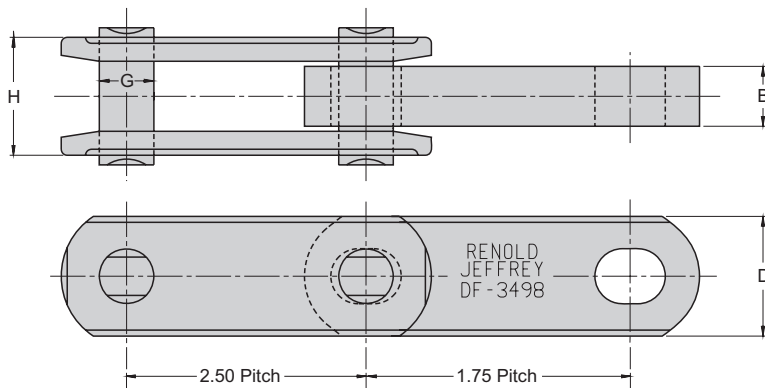

Induction hardened areas for extra wear life

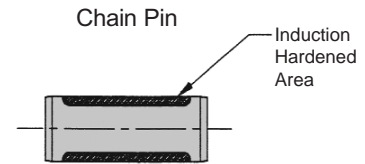
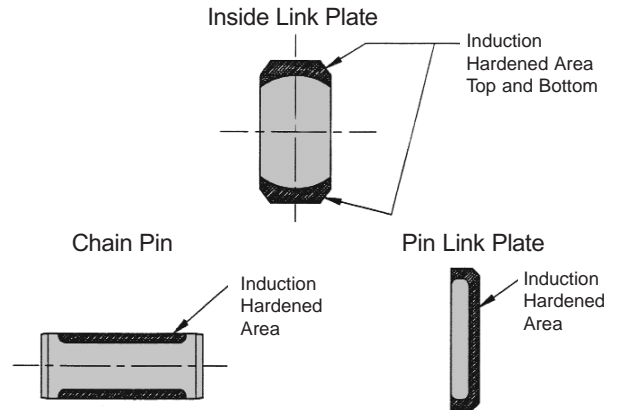

Corporate Headquarters

2307 Maden Drive
Morristown, TN 37813
Tel: (423) 586-1951
Tel: (800) 251-9012
Fax: (423) 581-2399

National Service Center

2305 Global Way
Hebron, KY 41048
Tel: (859) 334-8520
Tel: (800) 251-9012
Fax: (859) 334-8550

West Coast Service Center

2301 A Stagecoach Rd.
Stockton, CA 95215
Tel: (209) 466-4646
Tel: (800) 251-9012
Fax: (209) 466-1749