

Engineering Class Bucket Elevator Chain

Dimensions are in inches unless otherwise indicated.

Chain No.	Pitch Min	Inner Width Max	Knuckle/Bushing Diam Max	Plate Height Max	Plate Thick Max	Pin Diam Max	T	T ₁	U	d	h	s	s ₁	s ₂	Attachment		Average Ultimate Strength	Rated Working Load
															Type	No. Holes		
	A	B	C	D	E/F	G	T	T ₁	U	d	h	s	s ₁	s ₂			Lbs	Lbs
6956PB	6.000	3.000	1.750	3.000	0.500	1.000	7.250	—	9.560	0.688	1.875	2.500	—	—	K-24	4	144,500	16,000
6867R	6.000	3.000	1.750	3.250	0.500	1.000	7.000	12.000	14.000	0.563	2.500	3.500	—	3.500	K-44	8	170,000	14,000
6866R	6.000	2.500	2.375	3.000	0.500	1.250	6.313	—	9.810	0.688	2.375	2.250	—	—	K-2	4	167,000	17,400
6869R	6.000	3.720	2.375	4.000	0.625	1.250	9.000	13.000	15.000	0.688	3.000	2.750	—	4.500	K-44	8	267,000	22,000
6969R	6.000	3.720	2.500	4.000	0.625	1.500	9.000	13.000	15.000	0.688	3.000	2.750	—	4.500	K-44	8	275,000	30,000
6864R	7.000	3.720	2.375	4.000	0.625	1.250	9.000	13.000	15.000	0.688	3.000	3.750	2.750	5.500	K-443	10	267,000	22,000
6684R	7.000	3.750	2.500	4.000	0.625	1.375	9.000	13.000	15.000	0.688	3.000	3.750	2.750	5.500	K-443 K-44	10	270,000	24,000
6875R	7.000	3.750	2.500	4.000	0.625	1.500	9.000	13.000	15.000	0.688	3.000	3.750	2.750	5.500	K-443 K-44	10	275,000	30,000
6874	7.000	4.000	2.750	4.500	0.750 0.625	1.750	9.500	13.500	15.500	0.688	3.125	3.750	2.750	5.500	K-443 K-44	10	420,000	38,000

Contact Renold Jeffrey for weight specifications and for verification as dimensions are subject to change.

Cement Mill Chain

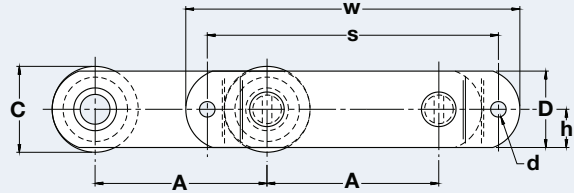
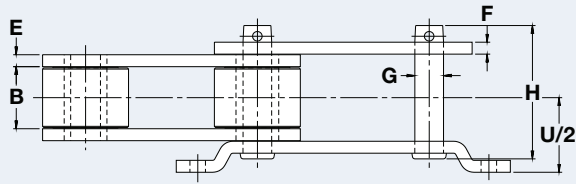

Engineering Class G-100 Super Capacity Bucket Elevator Chain

Dimensions are in inches unless otherwise indicated.

Chain No.	Pitch Min	Inner Width Max	Roller Diam Max	Plate Height Max	Plate Thick Max	Pin Diam Max	Pin Length Max						Average Ultimate Strength	Rated Working Load
	A	B	C	D	E/F	G	H	d	U/2	h	s	w	Lbs	Lbs
3252PR	9.000	2.625	3.000	2.500	0.500	1.000	5.422	0.688	3.359	1.250	14.000	16.500	116,000	12,650
4035PB	9.000	3.160	3.500	3.000	0.500	1.125	6.016	0.688	3.593	1.500	14.000	16.000	131,700	16,400
4065	9.000	3.060	4.250	3.500	0.625	1.250	6.484	0.688	3.938	1.750	14.000	16.500	215,000	19,000
4037PB	9.000	3.250	4.500	4.000	0.625	1.500	7.000	0.810	3.910	2.000	15.250	17.500	253,000	27,000

Contact Renold Jeffrey for weight specifications and for verification as dimensions are subject to change.

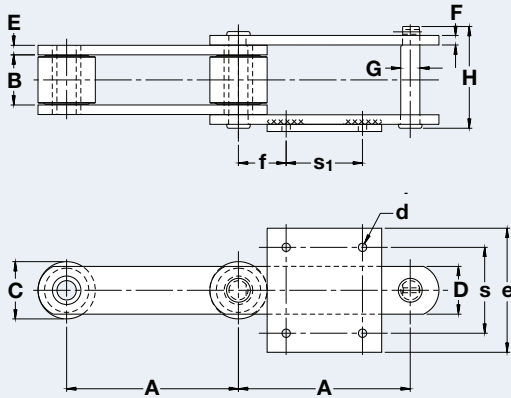

Style S (Straight Sidebar)

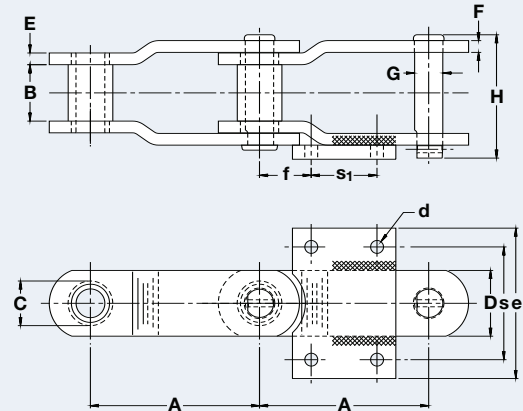

Style O (Offset Sidebar)

Engineering Class G-9 Super Capacity Bucket Elevator Chain

Dimensions are in inches unless otherwise indicated.

Chain No.	Sidebar Style	Pitch Min	Inner Width Max	Roller/Bushing Diam Max	Plate Height Max	Plate Thick Max	Pin Diam Max	Pin Length Max						Average Ultimate Strength	Rated Working Load
		A	B	C	D	E/F	G	H	d	e	f	s	s ₁	Lbs	Lbs
6859R*	O	9.000	2.500	1.750	2.500	0.500	1.000	5.390	0.660	6.000	3.250	4.000	3.500	130,000	14,000
6881AR*	O	9.000	3.000	2.375	3.500	0.625	1.500	6.563	0.660	8.000	2.750	5.500	3.500	260,000	24,500
6889PB*	O	9.000	2.750	2.750	4.000	0.625	1.623	6.188	0.690	7.500	2.500	6.000	4.000	260,000	26,000
3252PR	S	9.000	2.625	3.000	2.500	0.500	1.000	5.422	0.438	6.500	2.500	4.500	4.000	116,000	12,650
4065	S	9.000	3.060	4.250	3.500	0.625	1.250	6.484	0.690	8.000	2.750	6.000	3.500	215,000	19,000

*Denotes offset sidebar and stud bushing

Contact Renold Jeffrey for weight specifications and for verification as dimensions are subject to change.

Cement Mill Chain

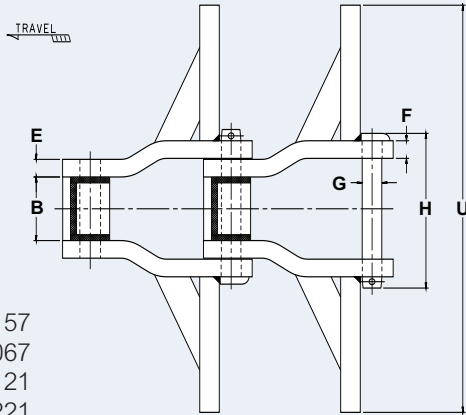

WS5157
WS6067
WS6121
WS6221
WS6267

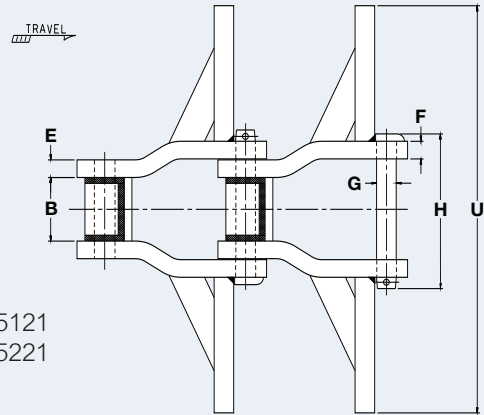

WS5121
WS5221

Engineering Class Hard Face Welded Steel Drag Chain

Dimensions are in inches unless otherwise indicated.

Chain No.	Pitch	Inner Width Max	Barrel Diam Max	Plate Height Max	Plate Thick Max	Pin Diam Max	Pin Length Max		Average Ultimate Strength	Rated Working Load
	A	B	C	D	E/F	G	H	U	Lbs	Lbs
WS5157H	6.050	3.000	1.750	2.500	0.625	1.125	6.875	8.000–21.000	180,000	18,200
WS6067HHF	9.000	3.625	2.500	2.500	0.750	1.250	8.018	10.000–24.000	230,000	24,300
WS6267HHF	9.000	3.625	2.500	2.500	0.750	1.375	8.062	10.000–20.000	210,000	26,700
WS5121HHF	9.000	3.625	2.500	2.500	1.125	1.250	9.873	10.000–30.000	275,000	27,600
WS5221HHF	9.000	3.625	2.500	2.500	1.125	1.375	9.813	10.000–30.000	305,000	30,300
WS6121HHF	9.000	3.625	2.500	2.500	1.125	1.250	9.875	10.000–30.000	275,000	27,600
WS6221HHF	9.000	3.625	2.500	2.500	1.125	1.375	9.813	10.000–30.000	305,000	30,300

Contact Renold Jeffrey for weight specifications and for verification as dimensions are subject to change.